

# SECURITY FRAMED WALL MIRROR

● Chase Mounted

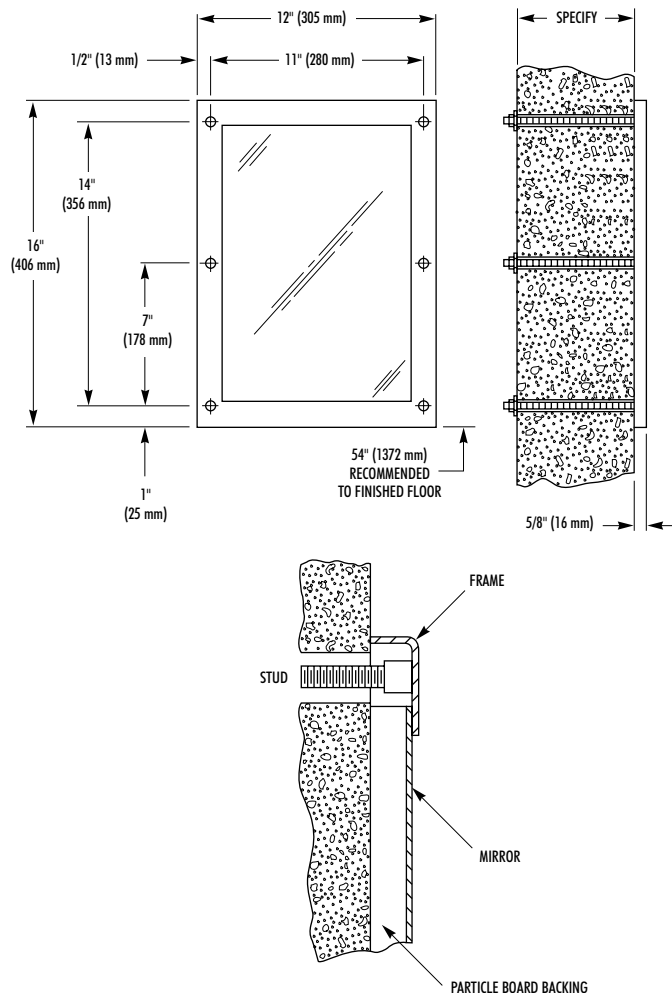

## CONSTRUCTION:

Frame is fabricated of type 304 (18-8), 14 gauge stainless steel, seamless construction, with exposed surfaces in architectural satin finish. Back of frame has welded anchor nuts to receive 1/4" - 20 studs (provided). Mirror material (specify below) held to frame by fiberboard backing. Nuts and washers included.

## MIRROR:

(must check one)

- MODEL SA01-1-TYPE 304 STAINLESS STEEL** mirror fabricated of 20 gauge, type 304 (18-8), stainless steel polished to a No. 8 architectural finish. Stretcher leveled for uniform finish. Very bright – excellent reflectivity, very slight polish grain.
- MODEL SA01-2-TYPE 430 STAINLESS STEEL** mirror fabricated of 20 gauge, type 430 stainless steel, bright annealed. Stretcher leveled for uniform finish. Surface is bright and smooth with mirror-like finish.
- MODEL SA01-4-TEMPERED GLASS** mirror is 1/4" thick, No. 1 quality glass, heat tempered without tong marks. Excellent reflectivity, difficult to break. If broken, mirror crumbles into small particles.
- MODEL SA01-5-PLEXIGLAS** mirror is 1/4" thick with excellent reflectivity. Surface subject to scratching and must not be cleaned with abrasive cleaners. (Plexiglas is a Trademark of Rohm & Haas)

WALL THICKNESS (must check one)	
<input type="checkbox"/> Up to 1"	<input type="checkbox"/> 1" to 6"
<input type="checkbox"/> 8"	<input type="checkbox"/> Over 8", Specify Thickness: _____
WALL TYPE (must check one)	
<input type="checkbox"/> Concrete	<input type="checkbox"/> Block
<input type="checkbox"/> Steel	<input type="checkbox"/> Other: _____

Document No. 9170

This information is subject to change without formal notice.  
1299RSSCJ



P.O. Box 309, Menomonee Falls, WI 53052-0309  
Phone 1-800-BRADLEY FAX 262-253-4161  
Web Site: <http://www.bradleycorp.com>  
Technical Information Fax Service: 1-800-BRADFAX