

SECURITY FRAMED WALL MIRROR

- Front Mounted

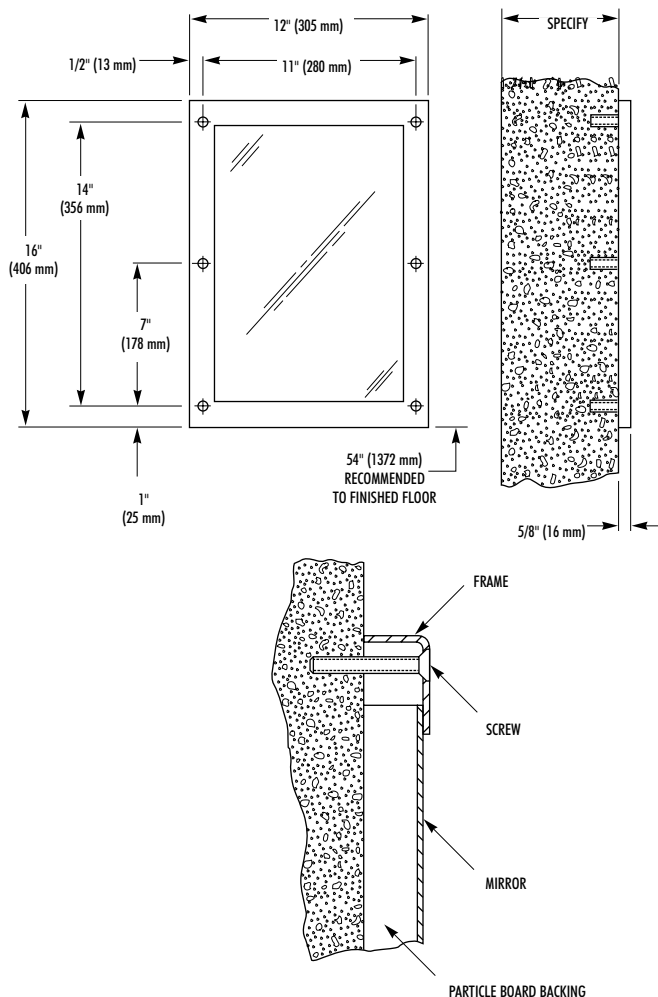

CONSTRUCTION:

Frame is fabricated of type 304 (18-8) 14 gauge stainless steel, seamless construction, with exposed surfaces in architectural satin finish. Unit supplied with 1/4" - 20 x 1-1/2" L torx-head screws for installation to wall anchors (not included). Torx driver available as option. Mirror material (specify below) held to frame by fiberboard backing.

MIRROR:

(must check one)

- SA03-1 **Bradex™**
TYPE 304 STAINLESS STEEL mirror fabricated of 20 gauge, type 304 (18-8) stainless steel polished to a No. 8 architectural finish. Stretcher leveled for uniform finish. Very bright - excellent reflectivity, very slight polish grain.
- SA03-2 **Bradex™**
TYPE 430 STAINLESS STEEL mirror fabricated of 20 gauge, type 430 stainless steel, bright annealed. Stretcher leveled for uniform finish. Surface is bright and smooth with mirror-like finish.
- SA03-4 **TEMPERED GLASS** mirror is 1/4" thick, No. 1 quality glass, heat tempered without tong marks. Excellent reflectivity, difficult to break. If broken, mirror crumbles into small particles.
- SA03-5 **PLEXIGLAS** mirror is 1/4" thick with excellent reflectivity. Surface subject to scratching and must not be cleaned with abrasive cleaners. (Plexiglas is a Trademark of Rohm & Haas).

Orders composed of products indicated as **Bradex™** will be available to ship in one week after receipt of order at the factory. There is no pricing penalty for this service from Bradley.

Document No. 9175

This information is subject to change without formal notice.
1299RSSCJ

Bradley 

P.O. Box 309, Menomonee Falls, WI 53052-0309
Phone 1-800-BRADLEY FAX 262-253-4161
Web Site: <http://www.bradleycorp.com>
Technical Information Fax Service: 1-800-BRADFAX