



# Technical Data

# SURFACE-MOUNTED HAND DRYER

## AutoPilot Operation

# B-708

### Specify Voltage Required:

- 115V AC, 20 Amp, 2300 Watts, 50/60 Hz, Single Phase, UL/c-UL Listed.
- 208-230V AC, 9-10 Amp, 1900-2300 Watts, 50/60 Hz, Single Phase, UL/c-UL Listed, VDE approved and CE Marked

Specify model number followed by voltage required. Example: B-708 115V for 115-volt hand dryer.



### \*RECOMMENDED MOUNTING HEIGHTS

Men's Washrooms	46" (1170mm)
Women's Washrooms	44" (1120mm)
Children's Washrooms, ages 3-9	32" (815mm)
Children's Washrooms, ages 9-12	36" (915mm)
Children's Washrooms, ages 12-15	40" (1015mm)
Children's Washrooms, ages 15-18	44" (1120mm)
For Barrier-Free Design	38" (965mm)

\*Bottom screw hole of mounting base to finish face of floor

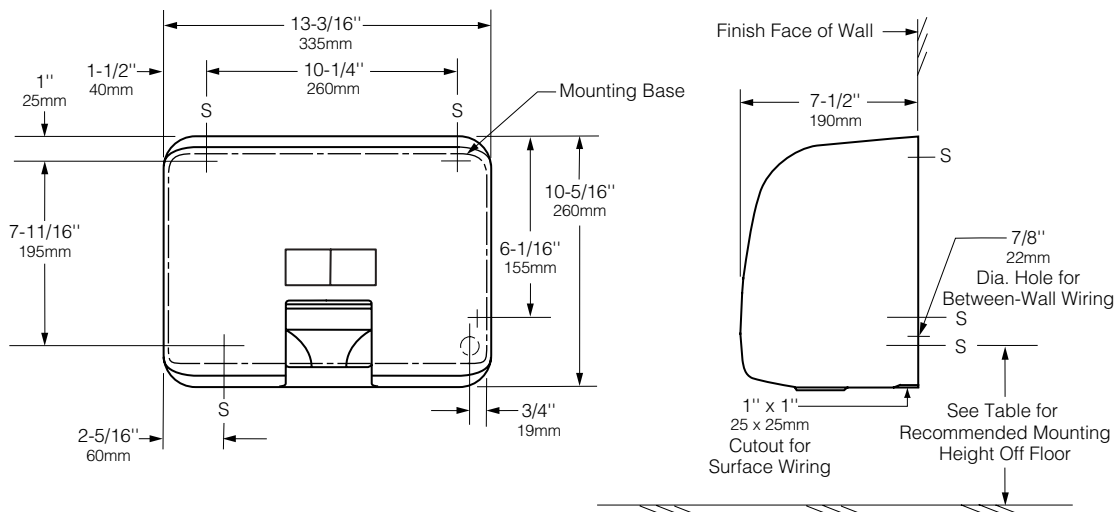

### MATERIALS:

**Cover** — One-piece, minimum 1/8" (3mm) thick, white iron-casting is finished in high-gloss, acid-resistant, multicoat vitreous enamel. Equipped with a two-position, self-returning, chrome-plated air-outlet nozzle. Graphic operating instructions are permanently fused with vitreous enamel cover for maximum vandal- and wear-resistance. Air-inlet and -outlet openings are equipped with vandal-resistant grilles. Cover is secured to mounting base with two concealed, vandal-resistant, recessed hex-screws.

**Mounting Base** — 14-gauge (2.0mm) plated steel with four 19/64" (8mm) diameter mounting holes.

**Motor** — Universal, 1/10 hp, 6200 rpm, on resilient mounting. Sealed ball bearing at drive-shaft end and self-lubricating sleeve bearing at nondrive end. Equipped with automatic thermal-overload switch.

**Fan** — Dynamically balanced, single-inlet centrifugal fan is mounted on motor shaft; directs airflow through heating element at 150 cfm.

**Heating Element** — Coiled nickel-chrome heating element is mounted in ceramic frame and protected by an automatic thermal-overload switch. Heating element, which is located on inlet side of fan, heats air without hot spots — inaccessible to vandals.

**Electronic Control** — Infrared sensor automatically turns dryer on when hands or self-returning nozzle are held under air-outlet opening and across path of sensor. Remove hands or release self-returning nozzle from path of sensor and dryer stops. Electronic sensor has automatic shutoff approximately 1-1/2 minutes after dryer turns on if an inanimate object is placed across air-outlet opening. After inanimate object is removed, electronic sensor automatically resets itself and dryer operates normally.

continued . . .

## OPERATION:

No-touch operation: electronic sensor automatically turns dryer on when hands or self-returning nozzle are held under air-outlet opening and across path of sensor. Two-position nozzle is adjustable to direct airflow: up position directs airflow down for hand drying and down position directs airflow up for face drying. After drying face, release nozzle and it automatically returns to up position. Remove hands or release self-returning nozzle from path of sensor and dryer stops. Dryer will not stop by itself before user is satisfied hands or face are dry. Dryer operates only when actually drying hands or face, which saves energy and operating costs. Electronic sensor will automatically shut dryer off 1-1/2 minutes after dryer turns on if inanimate object, such as tape or chewing gum, is placed across air-outlet opening. After inanimate object is removed, electronic sensor automatically resets itself and dryer operates normally.

**10-Year Limited Warranty** — In addition to Bobrick's one-year guarantee, Bobrick extends a limited 10-year warranty from the date of installation for Model B-708 hand dryer on all parts, except motor brushes, to the original owner of the installed unit against defects in factory workmanship or material under normal use and service. Motor brushes are warranted for three years from date of installation. This warranty is limited to the repair or exchange of defective parts at the option of Bobrick. See warranty card or Installation Instruction Sheet, Form No. 700-69, for full details.

## INSTALLATION:

**Wall preparation:** Secure mounting base on wall using template provided. For masonry walls, provide four 1/4" (6mm) expansion shields or anchors and secure with #14 (M6.3) sheet-metal screws (not furnished). For plaster or dry wall construction, provide concealed backing to comply with local building codes and secure with #14 x 2-3/4" (M6.3 x 70mm) or longer round-head sheet-metal screws or 1/4" (6mm) toggle bolts (not furnished). Provide electrical service from nearest distribution panel to dryer mounting base in conformance with local electrical codes.

### Wiring Instructions:

1. For 115-Volt Dryers — Connect ground wire to ground terminal marked  $\text{⏏}$ , the black or *hot* wire to terminal marked *L1*, and neutral or white wire to terminal marked *N*. **DEDICATED LINE IS REQUIRED FOR EACH 115-VOLT INSTALLATION.**
2. For 208–230-Volt Dryers — Connect ground wire to ground terminal marked  $\text{⏏}$  and the 208- or 230-volt wires to terminal marked *L1* and *L2*.

For installation instructions that include step-by-step installation procedures and details of electrical service connections, see Form No. 700-69, which is packed with each shipment. This form is also available in advance upon request.

## SPECIFICATION:

Surface-mounted hand dryer shall have a one-piece, cast-iron cover finished in high-gloss, acid-resistant, multicoat vitreous enamel. Cover shall be equipped with a two-position, self-returning, chrome-plated, vandal-resistant air-outlet nozzle that adjusts for hand and face drying and automatically returns to hand-drying position after face drying; prevents vandals from pouring liquids into dryer. Graphic operating instructions are permanently fused with vitreous enamel cover for maximum vandal- and wear-resistance. Motor shall be 1/10 hp, universal type on resilient mounting with sealed ball bearing at drive-shaft end and self-lubricating sleeve bearing at nondrive end; equipped with automatic thermal-overload switch. Heating element shall be located on inlet side of fan, shall heat air without hot spots, be inaccessible to vandals, and protected by an automatic thermal-overload switch. Electronic sensor shall automatically turn dryer on when hands or self-returning nozzle are held under air-outlet opening and across path of sensor. Dryer shall turn off automatically when hands are removed or self-returning nozzle is released. Sensor shall automatically shut dryer off approximately 1-1/2 minutes after dryer turns on if inanimate object is placed across air-outlet opening. After inanimate object is removed, electronic sensor shall automatically reset itself and dryer shall operate normally. Unit shall be UL/c-UL listed, VDE approved and CE marked. Unit shall be protected by a limited 10-year warranty on all parts except motor brushes. Motor brushes shall be warranted for three years from date of installation. Manufacturer's service and parts manual shall be provided to the building owner/manager upon completion of project.

**Surface-Mounted Hand Dryer shall be Model B-708 of Bobrick Washroom Equipment, Inc., Clifton Park, New York; Jackson, Tennessee; Los Angeles, California; Bobrick Washroom Equipment Company, Scarborough, Ontario; Bobrick Washroom Equipment Pty. Ltd., Australia; and Bobrick Washroom Equipment Limited, United Kingdom.**